

CENTERLINE SST

CSAT Webinar Series – May 28, 2026

About CenterLine

- Privately held, Windsor Ontario Canada based organization.
- Average annual revenues of over \$200M
- Over 43,670 m² (470,000 sq.ft.) of manufacturing space in four (4) facilities in Windsor housing five (5) divisions: **Machinery, Electrodes, Automation Components, Supersonic Spray Technologies (SST) and Mechatronics**
- Expertise in a variety of processes including **Resistance Welding, GMAW, Metal Forming, Mechanical Assembly, Cold Spray Coatings, Repairs & Feature Additions.**
- Nearly **850** employees in Windsor facilities, **1100** worldwide
- Main customers : **Aerospace & Defense End-users and Key OEM's, Energy/Oil & Gas, Automotive/Heavy Equipment, Glass/CPG**



Locations



CenterLine (Windsor) Limited

- Machinery Division
- Mechatronics Division
- Automation Components Division
- Electrodes & Allied Products Division
- Supersonic Spray Technologies Division

CenterLine Welding Products, Inc. (Troy location)

CenterLine SE USA (Birmingham location)

CenterLine De Mexico S.de R.L. de C.V (2 locations)

CenterLine Brasil Solda e Automação Ltda

CenterLine-Germany GmbH

CenterLine Romania S.R.L.

CenterLine India Pvt Ltd.

CenterLine Welding Technologies (Guangzhou) Co., Ltd.

International sales, service and manufacturing locations in
Canada, USA, Mexico, Brazil, Germany, Romania, India & China

SST Division Customers



SST™ Cold Spray Technology



Downstream Injection Cold Spray (SST)

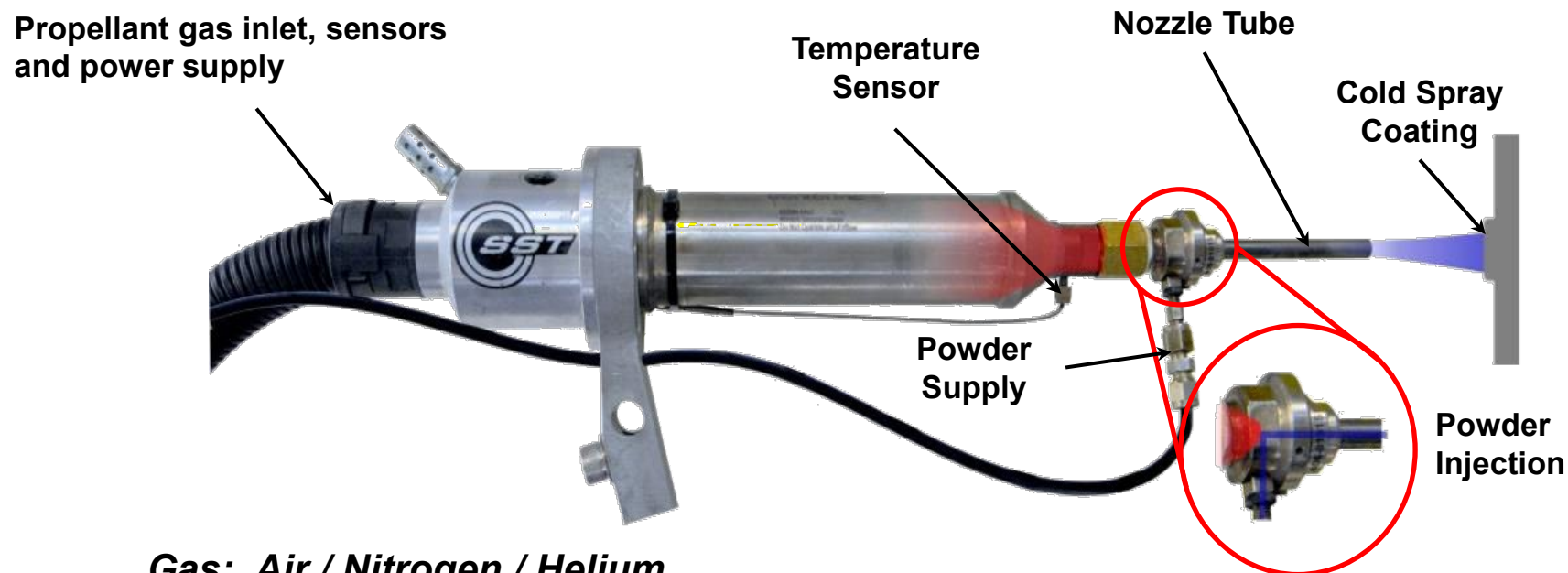

Gas: Air / Nitrogen / Helium

Gas Pressure SST P/PX: 60 - 250 psi (4-17 bar)

Gas Pressure SST EP/EPX: 100 - 500 psi (6-34 bar)

Gas Temperature: 20 – 550°C (68 - 1022 °F)

Particle Velocities: 300 - 600 / 900 m/s

SST Equipment

SST PX - Manual Spray Gun
250 PSI – 3.8KW



SST PX - Robotic Spray Gun
250 PSI- 4.25KW



SST EPX – Robotic Spray Gun
500 PSI – 15 KW



SST Integrated Solution Examples



Consumables & Accessories



**When spraying 2.1" ID bore,
the SOD is about 5-6 mm.**



**UltiLife™ & UltiFlow™
KN Series Modular Nozzle
System**



Calibration Kit



**Air Prep Unit
Class 2 Air**



Powder Feeders





SST ULTRA PORTABLE PX SUITCASE

CenterLine (SST) Smart Repair

Portable Conex (or Trailer)
Centerline SST PX Cold Spray
system

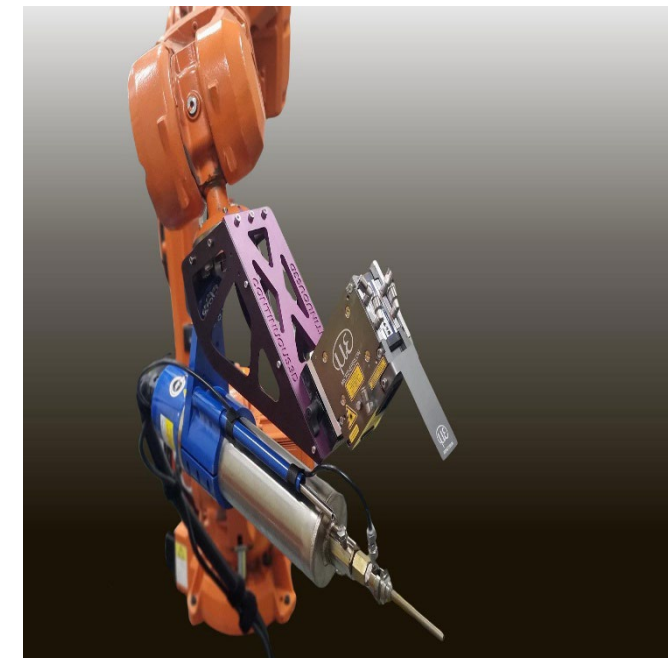

SST ULTRA PORTABLE

0.5 Liter capacity



3.8 Kw Spray Gun
with 10' of cable

HMI to program
Gun Temperature

Gun Gas Regulator

Gun Gas Pressure



Gun Gas Supply

Gas Supply

Control Panel

Gun Cable Electrical
Connector

This is a concept End Product may
not be exactly as shown

SST Revised ULTRA PORTABLE



CenterLine (SST) Smart Repair

CONTINUOUS3D



CenterLine (SST) Smart Repair

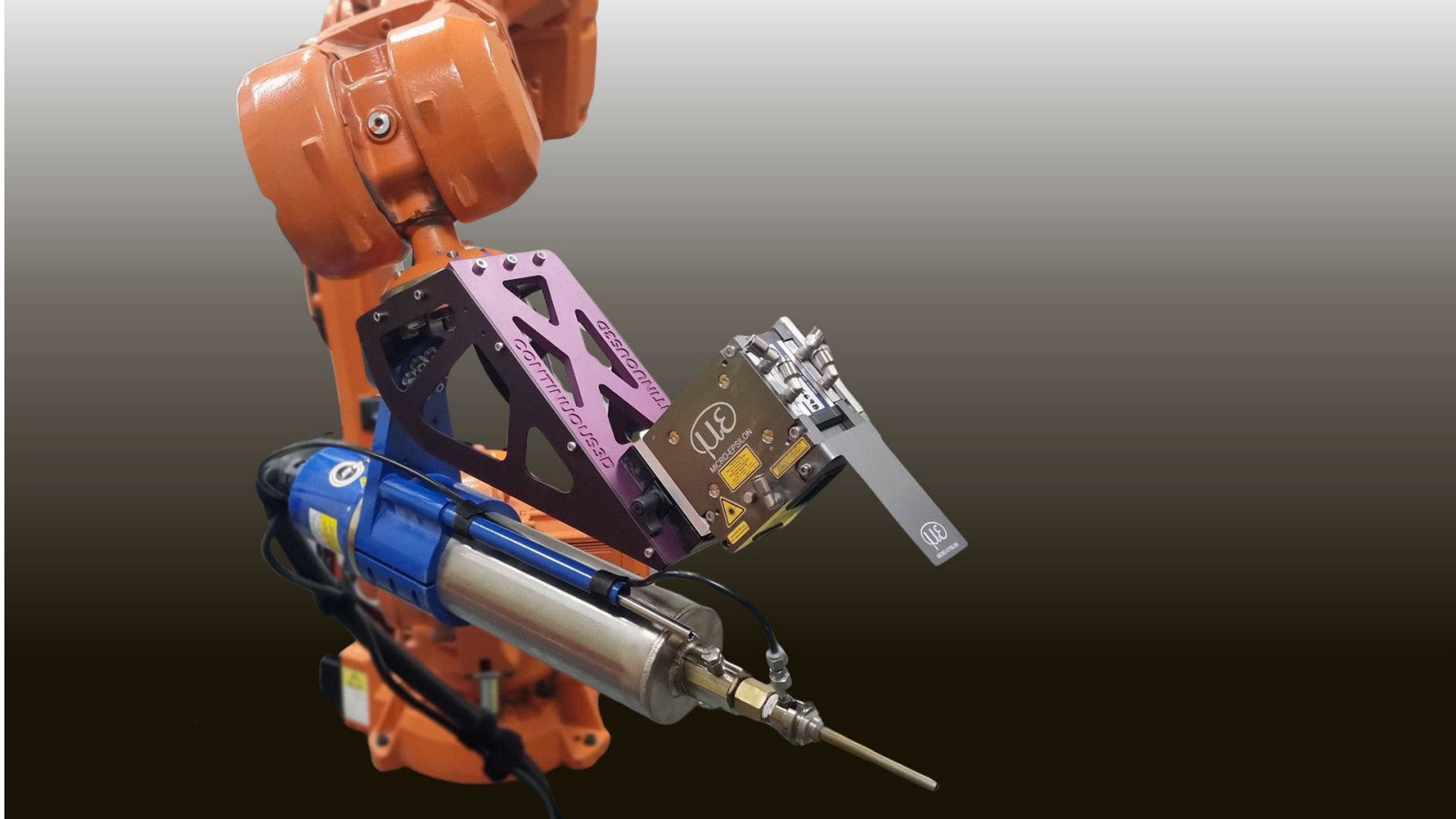

CenterLine (SST) Smart Repair Scan Part

Robot speed: 1.00

Model Tree

- IRB2600_20kg-165_LINK4_CAD_re
- IRB2600_20kg-165_LINKS_CAI
- IRB2600_20kg-165_LINK6_
- tool0_Rob1
- Rob2_Holder
 - Gearbox - Bou
 - Frame_Gear
 - SF_1
- IRB2600 Frame (Do Not Delete)
- IRB4600_45kg-205_BASE_CAD_rev04
- IRB4600_45kg-205_LINK1_CAD_rev04
- IRB4600_45kg-205_LINK2_CAD_rev04
- IRB4600_45kg-205_LINK3_CAD_rev04
- IRB4600_45kg-205_LINK4_CAD_re
- IRB4600_45kg-205_LINK5_CAI
- IRB4600_45kg-205_LINK6_
- tool0_Rob2
 - Centrefline gun Ass
 - Gun_TCP
 - scanner_2900
 - Sensor TCP
 - Frame 14
 - LaserScanner_E
 - LaserScann
 - machining bra
 - CenterlineGunSS_2
 - Bracket - C3D - Ce
 - Bracket - C3D - Center
 - ColdSprayGun
 - Datum
 - TCP
 - ColdSprayGun
 - ColdSprayGun
- CalibrationBlock
- Calibration block
- WobjFlange
- Sample 4
- Sample 4 RefFrame

Main Window

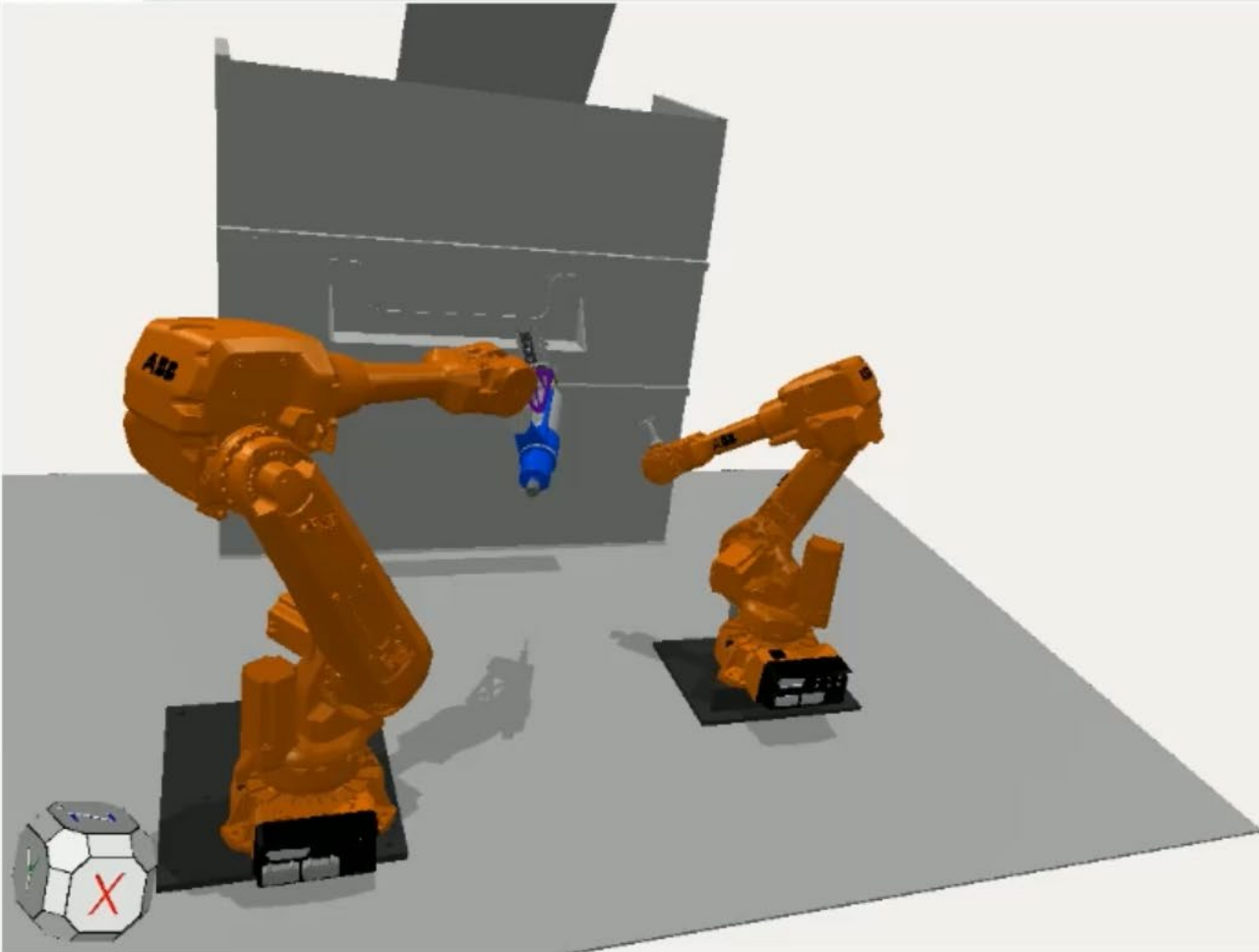

Model Settings

SF_1

Model Location (x, y, z, rx, ry, rz)

0.000	0.000	0.000	0.000	-0.000	0.000
-------	-------	-------	-------	--------	-------

Clear

tory: D:\C3D\2025.08.04, Gearbox MTS\Gearbox_Pose1

Record Stop Replay Real-time

Insert CAD file

Extraction: Extract all

Filter:

Console

DEBUG: Container starting fusion thread with 3 algorithms, has_source=false
WARNING: FusionTools::Overflow - detected a timestamp overflow on device 3, old time 9223372036854775808, new time 57890000691

Ready License is activated

CONTINUOUS3D

CenterLine (SST) Smart Repair

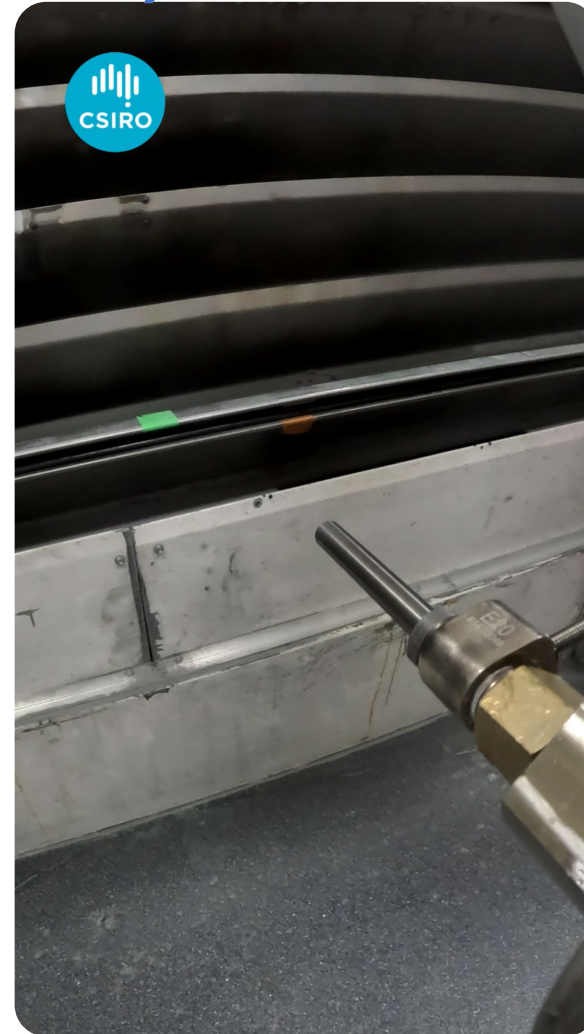

N2 – 450 °C @ 450 psi
WC nozzle – SoD: 13 mm
Traverse speed: 25 mm/s
Spray time (on flange): ~ 2.5 minutes
Powder used (Approx.): ~ 33 grams

CenterLine (SST) Smart Repair

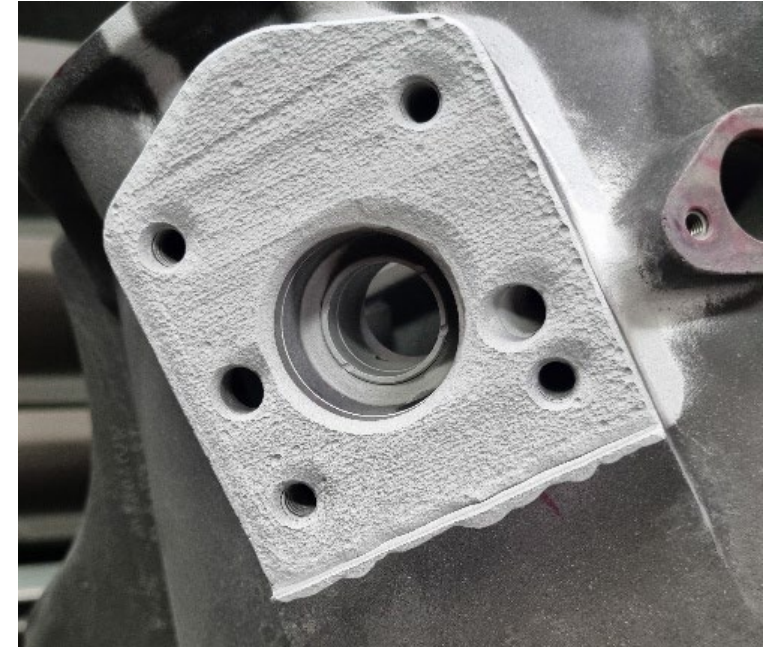
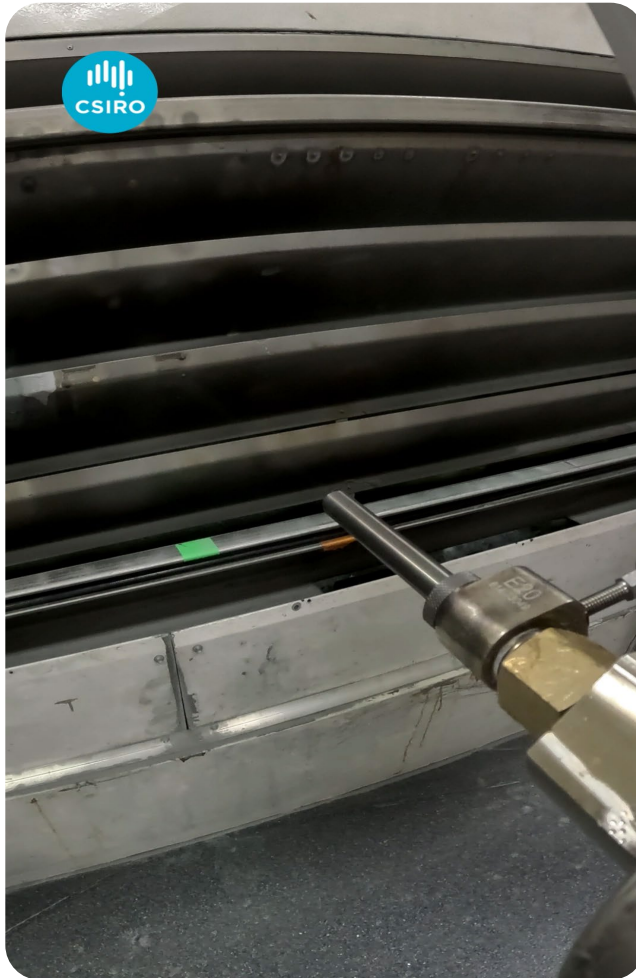

N2 – 450 °C @ 450 psi
WC nozzle – SoD: 13 mm
Traverse speed: 25 mm/s
Spray time (on flange): ~ 7.5 minutes
Powder used (Approx.): ~ 90 grams

CenterLine (SST) Smart Repair

Repairing Chamfered holes on Aircraft panels

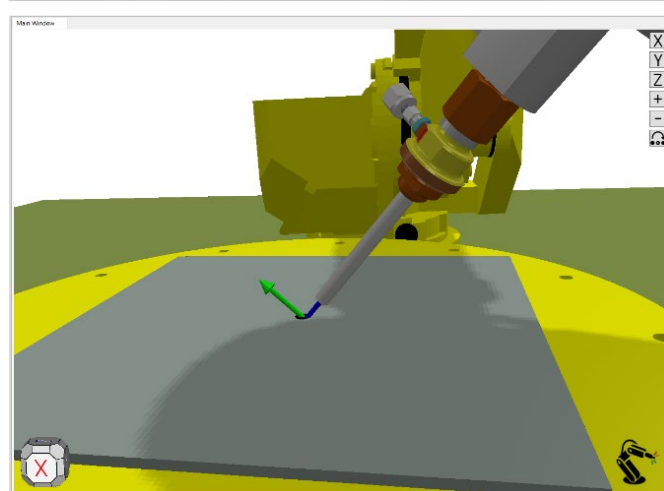

CenterLine (SST) Smart Repair

Scan Hole



- **An 6mm aluminum AA 5083 test plate was used.**
- **9.5mm diameter holes were drilled**
- **A 45-degree chamfer was added, making the top diameter of the hole ~ 12.3 mm.**

CenterLine (SST) Smart Repair

Toolpath Generation

CONTINUOUS3D



Spiral toolpath with 3 spiral arms

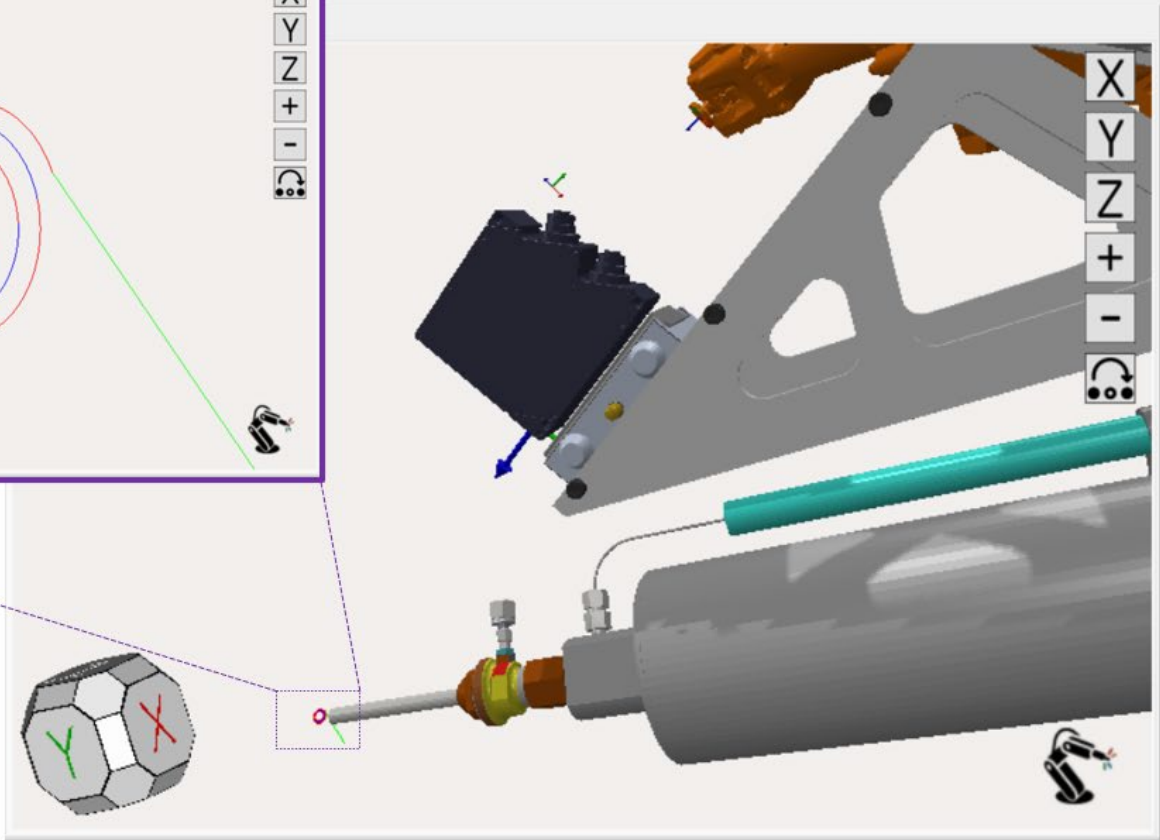

CenterLine (SST) Smart Repair

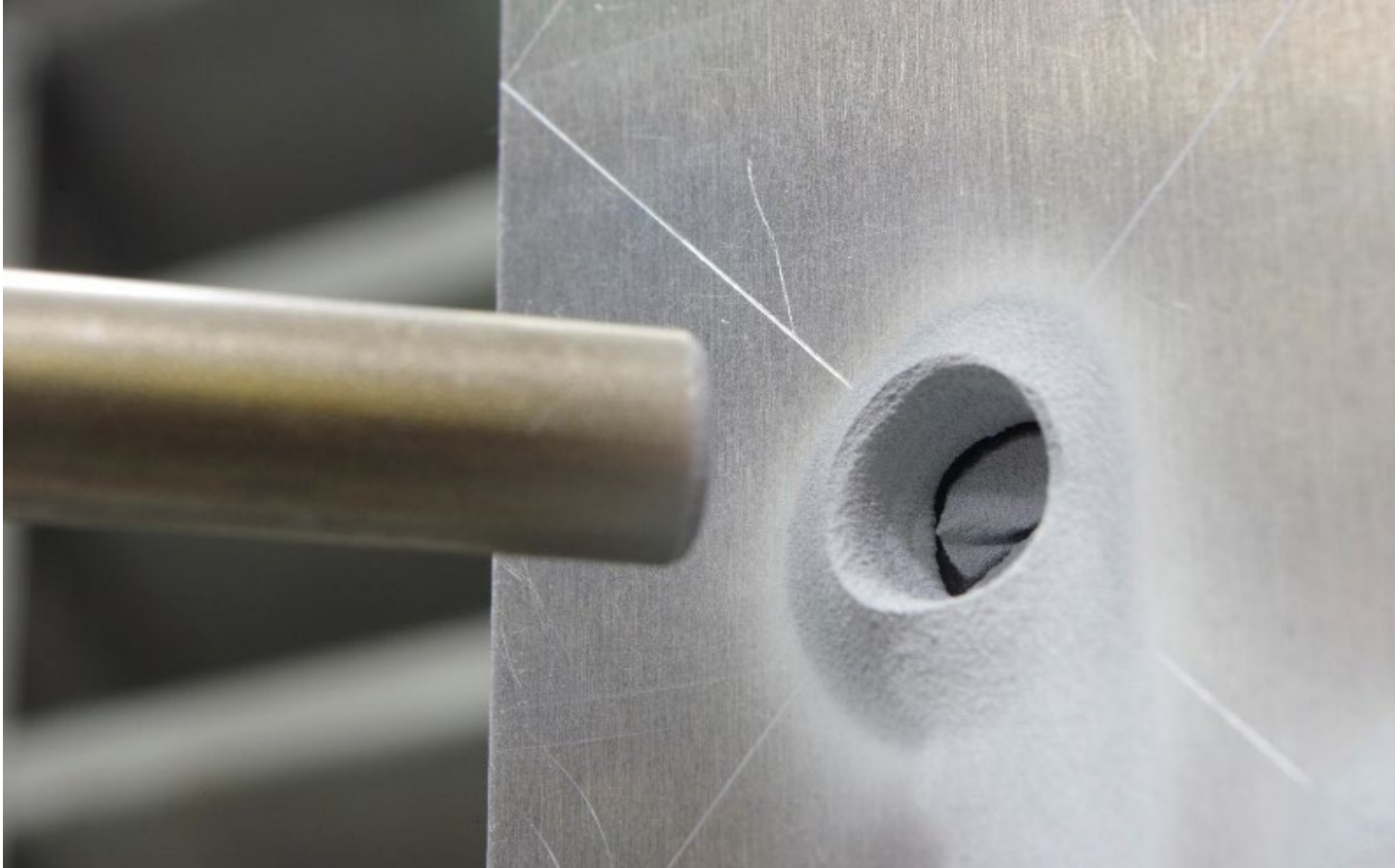

Open Discussion

